

SURFACE MINING TECHNOLOGY 2020

GROUND ENGAGING TOOLS (G.E.T.)

GROUND ENGAGING TOOLS (G.E.T.)

No matter what your commodity, we have a full range of G.E.T. (Ground Engaging Tools) to ensure your cast lip remains productive and delivers optimal performance. Our range is available for overburden application with dragline machines, to heavy duty excavator applications, we have a G.E.T. range suitable for your needs. Our G.E.T. is engineered to ensure there are no compromises between productivity and reliability.

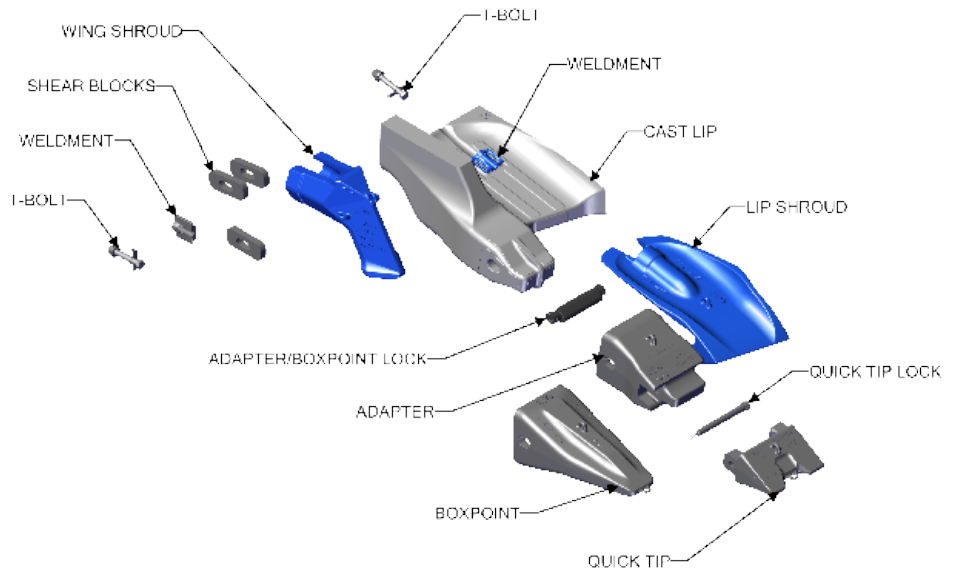

For more information about our GET range, please visit http://www.cqmsrazer.com/product_category/get-and-lock-systems/

FIGURE 1. Cast lip and G.E.T. labels

CONTENTS

500CPX SERIES TEETH	3
750CPX SERIES TEETH	4
CPX LOCK.....	5
BOXPOINTS.....	6
WHEEL LOADER TEETH.....	7
ADAPTERS	8
WEDGELOCK™	9
WEDGETAIL™	10
WEDGELOCK™ AND WEDGETAIL™ REPLACEMENT & SEAL KITS	11
FX ADAPTER RANGE.....	12
CAST LIP SHROUDS	13
DRAGLINE LIP SHROUDS.....	16
CAST LIP WING SHROUDS.....	17
46/57m³ CLASS HURRICANE™ WING SHROUDS.....	18
70/84/100m³ CLASS HURRICANE™ WING SHROUDS	19
46/57m³ CLASS EARTHEATER™ WING SHROUDS.....	20
84m³ CLASS EARTHEATER™ WING SHROUDS.....	21
SHEAR BLOCKS	22
WELDMENTS.....	23
T-BOLT KITS.....	24
HEEL SHROUDS	25

500CPX SERIES TEETH

www.cqmsrazer.com

DRAWING NO: CG-0015-1 REV NO: D

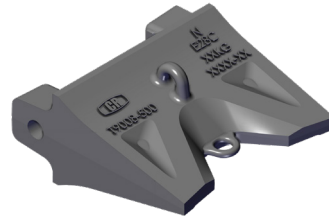
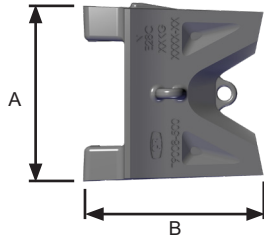

T9008-500CPX



T9009-500CPX

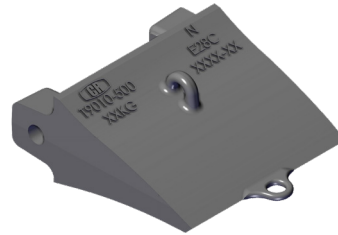

T9010-500CPX



T9018-500CPX



T9030-500CPX

VALUE ADD

PTAW AND RTO
APPLICATION IS AVAILABLE

LOCKING KITS

M500CPX

PART NO.	DIMENSIONS mm (in)			TYPE	APPLICATION	PRODUCT PROPERTIES			MASS kg (lbs)
	A	B	C			IMPACT	ABRASION	PENETRATION	
T9008-500CPX	376 (14.80)	381 (15.00)	175 (6.89)	TWIN TIGER	GENERAL PURPOSE	MODERATE	MODERATE	HIGH	65 (143.0)
T9009-500CPX	376 (14.80)	371 (14.61)	173 (6.81)	PANEL	OVER BURDEN	MODERATE	MODERATE	STANDARD	64 (140.8)
T9010-500CPX	376 (14.80)	386 (15.20)	165 (6.50)	BELOW CENTRELINE PANEL	DRAGLINE	LOW	MODERATE	HIGH	64 (140.8)
T9018-500CPX	398 (15.67)	361 (14.21)	189 (7.44)	HEAVY DUTY TWIN TIGER	HARD ROCK	MODERATE	HIGH	HIGH	71 (156.2)
T9030-500CPX	370 (14.57)	414 (16.30)	193 (7.60)	EXTREME DUTY	HARD ROCK	HIGH	HIGH	LOW	99 (217.8)

500PRS SERIES TEETH

www.cqmsrazer.com

DRAWING NO: CG-0015-1 REV NO: D

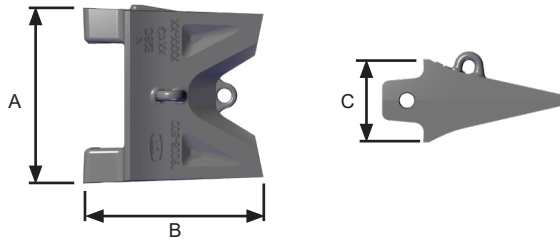

T9008-500PRS

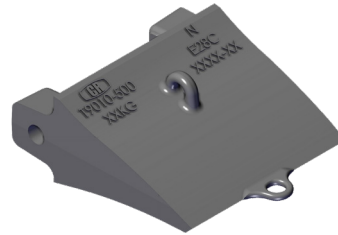

T9010-500PRS

VALUE ADD

PTAW AND RTO
APPLICATION IS AVAILABLE

LOCKING KITS

M500CPX

PART NO.	DIMENSIONS mm (in)			TYPE	APPLICATION	PRODUCT PROPERTIES			MASS kg (lbs)
	A	B	C			IMPACT	ABRASION	PENETRATION	
T9008-500PRS	376 (14.80)	381 (15.00)	175 (6.89)	TWIN TIGER	GENERAL PURPOSE	MODERATE	MODERATE	HIGH	65 (143.0)
T9010-500PRS	376 (14.80)	386 (15.20)	165 (6.50)	BELOW CENTRELINE PANEL	DRAGLINE	LOW	MODERATE	HIGH	64 (140.8)

750CPX SERIES TEETH

www.cqmsrazer.com

DRAWING NO: CG-0014-1 REV NO: D

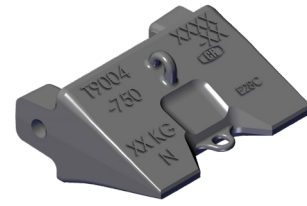
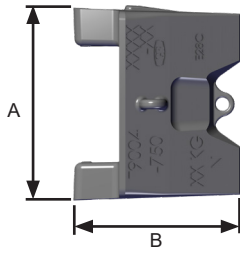

T9004-750CPX

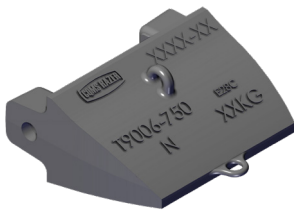

T9006-750CPX

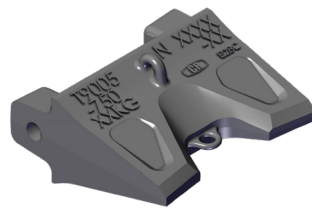

T9005-750CPX

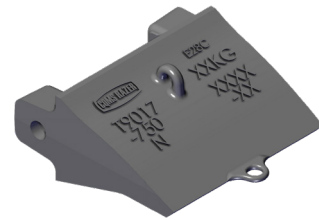

T9017-750CPX



T9016-750CPX

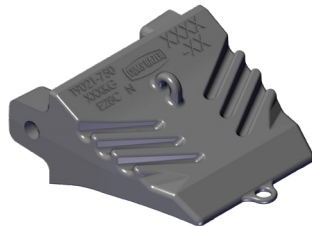

T9021-750CPX



T9030-750CPX

VALUE ADD

PTAW AND RTO APPLICATION IS AVAILABLE

LOCKING KITS

M750CPX

PART NO.	DIMENSIONS mm (in)			TYPE	APPLICATION	PRODUCT PROPERTIES			MASS kg (lbs)
	A	B	C			IMPACT	ABRASION	PENETRATION	
T9004-750 CPX	436 (17.17)	376 (14.80)	210 (8.27)	TIGER	GENERAL PURPOSE	MODERATE	MODERATE	STANDARD	90 (198.0)
T9005-750 CPX	436 (17.17)	403 (15.87)	196 (7.72)	TWIN TIGER	GENERAL PURPOSE	MODERATE	MODERATE	HIGH	86 (189.2)
T9006-750 CPX	436 (17.17)	379 (14.92)	197 (7.76)	BELOW CENTRELINE PANEL	DRAGLINE	LOW	MODERATE	HIGH	92 (202.4)
T9016-750 CPX	435 (17.13)	389 (15.31)	220 (8.66)	SLIMLINE TWIN TIGER	OVER BURDEN	LOW	LOW	HIGH	85.8 (188.8)
T9017-750 CPX	436 (17.17)	411 (16.18)	195 (7.68)	BELOW CENTRELINE PANEL	DRAGLINE	LOW	MODERATE	HIGH	87 (191.4)
T9021-750 CPX	436 (17.17)	465 (18.31)	220 (8.66)	HIGH PENETRATION	DRAGLINE	LOW	MODERATE	HIGH	107 (235.4)
T9030-750 CPX	428 (16.85)	458 (18.03)	216 (8.50)	HEAVY DUTY PANEL	HEAVY DUTY	HIGH	HIGH	STANDARD	138 (303.6)

CPX LOCK

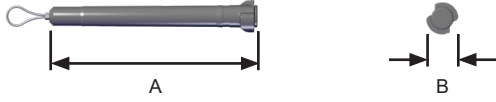

M500CPX

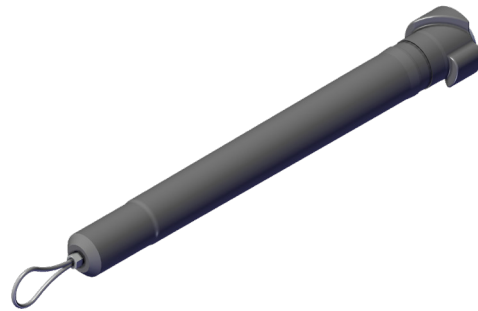

M750CPX

PART NO.	DIMENSIONS mm (in)		RETAINS	MASS kg (lbs)
	A	B		
M500CPX	329 (12.95)	51 (2.00)	ALL 500CPX SERIES TEETH	2 (4.4)
M750CPX	395 (15.55)	56 (2.20)	ALL 750CPX SERIES TEETH	3 (6.6)

BOXPOINTS

www.cqmsrazer.com

DRAWING NO: CG-0019-1 REV NO: F

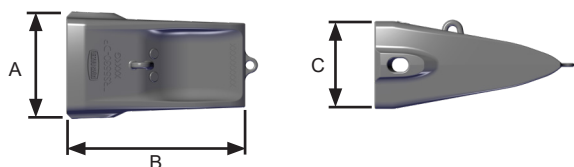

ROCK ABRASION



DOUBLE PANEL SOLID POINT



SUPER PENETRATOR



LONG ROCK PENETRATOR



HEAVY ROCK



HEAVY DUTY

VALUE ADD
PTAW AND RTO APPLICATION IS AVAILABLE
LOCKING KITS
WEDGELOCK™ SPIGOT WEDGELOCK™ WEDGETAIL™

PART NO.	DIMENSIONS mm (in)			TYPE	APPLICATION?	PRODUCT PROPERTIES?			MASS kg (lbs)
	A	B	C			IMPACT	ABRASION	PENETRATION	
TRS3530-DP	290 (11.42)	540 (21.26)	240 (9.45)	DOUBLE PANEL	GENERAL PURPOSE	LOW - MODERATE	LOW	MODERATE - HIGH	98 (215.6)
TDH5030-DP	372 (14.65)	620 (24.41)	299 (11.77)		GENERAL PURPOSE	LOW - MODERATE	LOW	MODERATE - HIGH	146 (321.2)
TRS5530-DP	373 (14.69)	620 (24.41)	290 (11.42)		GENERAL PURPOSE	LOW - MODERATE	LOW	MODERATE - HIGH	158 (347.6)
TRS6030-DP	386 (15.20)	650 (25.59)	326 (12.83)		GENERAL PURPOSE	LOW - MODERATE	LOW	MODERATE - HIGH	180 (396.0)
TRS7030-DP	398 (15.67)	760 (29.92)	361 (14.21)		GENERAL PURPOSE	LOW - MODERATE	LOW	MODERATE - HIGH	303 (666.6)
TDH7035-DP	370 (14.57)	820 (32.28)	410 (16.14)		GENERAL PURPOSE	LOW - MODERATE	LOW	MODERATE - HIGH	383 (842.6)
TRS1530-RA	213 (8.39)	506 (19.92)	212 (8.35)	ROCK ABRASION	HIGH PENETRATION	MODERATE - HIGH	HIGH	MODERATE - HIGH	56 (123.2)
TRS3530-RA	288 (11.34)	540 (21.26)	240 (9.45)		HIGH PENETRATION	MODERATE - HIGH	HIGH	MODERATE - HIGH	97 (213.4)
TRS4530-RA	344 (13.54)	555 (21.85)	274 (10.79)		HIGH PENETRATION	MODERATE - HIGH	HIGH	MODERATE - HIGH	124 (272.8)
TRS5530-RA	372 (14.65)	620 (24.41)	308 (12.13)		HIGH PENETRATION	MODERATE - HIGH	HIGH	MODERATE - HIGH	169 (371.8)
TRS7030-RA	401 (15.79)	820 (32.28)	366 (14.41)		HIGH PENETRATION	MODERATE - HIGH	HIGH	MODERATE - HIGH	322 (708.4)
TRS1530-SP	213 (8.39)	487 (19.17)	196 (7.72)		SUPER PENETRATOR	HIGH PENETRATION	MODERATE	MODERATE - HIGH	HIGH
TRS2530-SP	255 (10.04)	538 (21.18)	220 (8.66)	HIGH PENETRATION		MODERATE	MODERATE - HIGH	HIGH	71 (156.2)
TRS3530-SP	285 (11.22)	515 (20.28)	235 (9.25)	HIGH PENETRATION		MODERATE	MODERATE - HIGH	HIGH	79 (173.8)
TRS6030-SP	390 (15.35)	770 (30.31)	360 (14.17)	HIGH PENETRATION		MODERATE	MODERATE - HIGH	HIGH	317 (697.4)
TDH7030-SP	384 (15.12)	810 (31.89)	399 (15.70)	HIGH PENETRATION		MODERATE	MODERATE - HIGH	HIGH	334 (734.8)
TRS6030-LRP	395 (15.55)	702 (27.64)	329 (12.95)	LONG ROCK PENETRATOR		HIGH PENETRATION	LOW - MODERATE	LOW - MODERATE	MODERATE - HIGH
TRS3530-HR	288 (11.34)	591 (23.26)	274 (10.78)	HEAVY ROCK	GENERAL PURPOSE	MODERATE - HIGH	MODERATE - HIGH	LOW - MODERATE	115 (253)
TRS4530-XH	344 (13.54)	639 (25.16)	280 (11.02)	HEAVY DUTY	HIGH ABRASION	MODERATE - HIGH	HIGH	MODERATE	156.9 (345.9)

WHEEL LOADER TEETH

www.cqmsrazer.com

DRAWING NO: CG-0019-1 REV NO: F

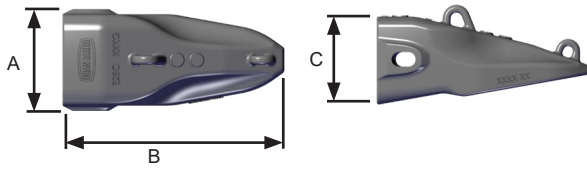

WHEEL LOADER ROCK PENETRATOR 2



WHEEL LOADER ROCK ABRASION



WHEEL LOADER PENETRATOR

VALUE ADD

PTAW AND RTO
APPLICATION IS AVAILABLE

LOCKING KITS

SPIGOT WEDGELOCK™

PART NO.	DIMENSIONS mm (in)			TYPE	APPLICATION?	PRODUCT PROPERTIES			MASS kg (lbs)
	A	B	C			IMPACT	ABRASION	PENETRATION	
TRS2535-RP2	250 (9.84)	500 (19.69)	233 (9.17)	ROCK PENETRATION	HIGH PENETRATION	MODERATE - HIGH	MODERATE	MODERATE	74 (162.8)
TRS2535-RA	250 (9.84)	548 (21.57)	227 (8.94)	ROCK ABRASION	HIGH PENETRATION	MODERATE - HIGH	MODERATE - HIGH	MODERATE - HIGH	89 (195.8)
TRS2535-LP	250 (9.84)	551 (21.69)	250 (9.84)	LOADER PENETRATOR	HIGH PENETRATION	MODERATE	HIGH	MODERATE - HIGH	117 (257.4)

ADAPTERS

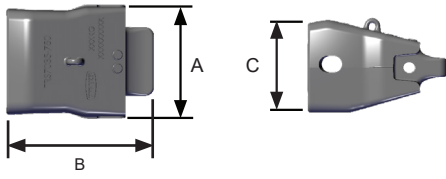

ADAPTER EXAMPLE (TRS6030-500)

VALUE ADD
PTAW AND RTO
APPLICATION IS AVAILABLE

PART NO.	DIMENSIONS mm (in)			LOCKING KIT	APPLICATION	MASS kg (lbs)
	A	B	C			
TDH5030-500	372 (14.65)	464 (18.27)	304 (11.97)	TDS50W-M	GENERAL PURPOSE	166 (365.2)
TRS5531-500	365 (14.37)	464 (18.27)	312 (12.28)	TDS50W-M	GENERAL PURPOSE	180 (396.0)
TRS6030-500	495 (19.49)	495 (19.49)	340 (13.39)	TDS60W-M	GENERAL PURPOSE	176 (387.2)
TDH7030-500	366 (14.41)	525 (20.67)	389 (15.31)	TDS60W-M	GENERAL PURPOSE	198 (435.6)
TRS6030-750	420 (16.54)	505 (19.88)	367 (14.45)	TDS60W-M	GENERAL PURPOSE	215 (473.0)
TRS7030-750	405 (15.94)	544 (21.42)	348 (13.70)	TDS70W-1	GENERAL PURPOSE	221 (486.2)
TDH7030-750	407 (16.02)	538 (21.18)	381 (15.00)	TDS60W-M	GENERAL PURPOSE	212 (466.4)
TRS7035-750	420 (16.54)	543 (21.38)	358 (14.09)	TDS70W-1	GENERAL PURPOSE	247 (543.4)
TDH7035-750	430 (16.93)	560 (22.05)	422 (16.61)	TDS60W-M	GENERAL PURPOSE	304 (668.8)

WEDGELOCK™

www.cqmsrazer.com

DRAWING NO: CG-0024-1 REV NO: E

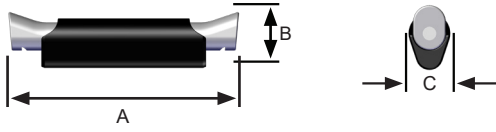

SPIGOT WEDGELOCK™



WEDGELOCK™

PART NO.	DIMENSIONS mm (in)			CAST LIP APPLICATION (NOSE DEFINITION)	MASS kg (lbs)
	A	B	C		
TRS20SW	211 (8.30)	71 (2.79)	42 (1.65)	TRS25	2.9 (6.4)
TRS30SW	258 (10.15)	71 (2.79)	44 (1.73)	TRS30	3.2 (7.0)
TRS40W	348 (15.36)	82 (3.28)	55 (2.2)	TRS45	6 (13.2)
TRS50W	376 (15.04)	84 (3.36)	55 (2.2)	TDH50, TRS50, TRS55	7 (15.4)
TRS60W	381 (15.24)	98 (3.92)	70 (2.8)	TRS60	10 (22)
TRS70W	400 (16)	100 (4)	7 (3)	TRS70	12.6 (27.7)

WEDGETAIL™

www.cqmsrazer.com

DRAWING NO: CG-0024-1 REV NO: E

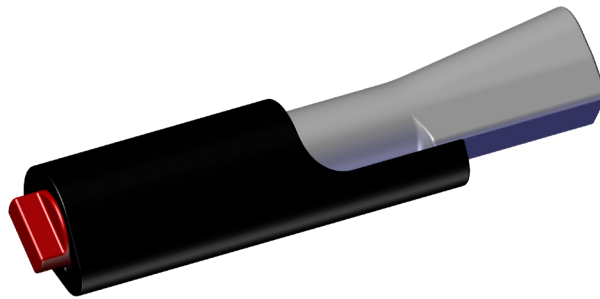
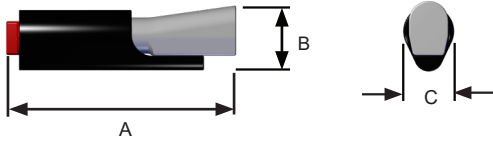

WEDGETAIL™
TDS60WT-1

PART NO.	DIMENSIONS mm (in)			CAST LIP APPLICATION (NOSE DEFINITION)	RETAINS ADAPTER/BOXPOINT	MASS kg (lbs)
	A	B	C			
TRS10WT	193 (7.6)	57 (2.24)	38 (1.5)	TRS15	TRS15 SERIES	1.71 (3.8)
TRS20WT	201 (7.91)	72 (2.83)	44 (1.73)	TRS25	TRS25 SERIES	3 (6.6)
TRS30WT	250 (9.84)	72 (2.83)	45 (1.77)	TRS35	TRS35 SERIES	3 (6.6)
TRS40WT	334 (13.15)	82 (3.23)	55 (2.17)	TRS45	TRS45 SERIES	6.29 (13.8)
TRS50WT	334 (13.15)	82 (3.23)	55 (2.17)	TRS55	TRS55 SERIES	6.36 (14.0)
TDS60WT-1	342 (13.46)	96 (3.77)	69 (2.71)	TRS60	TRS60 SERIES	10 (22.0)
TDS70WT-1	359 (14.13)	100 (3.93)	75 (2.95)	TRS70	TRS70 SERIES	12 (26.4)

WEDGELOCK™ AND WEDGETAIL™ REPLACEMENT & SEAL KITS

www.cgmsrazer.com

DRAWING NO: CG-0048-1 REV NO: E

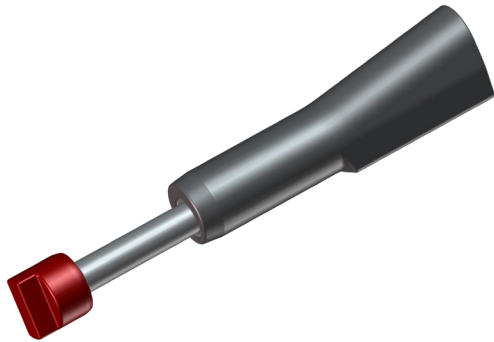

TEARDROP WEDGETAIL™ REPLACEMENT KIT



WEDGELOCK™ REPLACEMENT KIT

PART NO.	CAST LIP APPLICATION	LOCKING KIT	TYPE	MASS kg (lbs)
REPLACEMENT KITS				
TDS20/30SWR	TRS25 / TRS35,	TDS20SW /TDS30SW	WEDGELOCK™	1.8 (4.0)
TDS40WR-1	TRS45	TDS40W-1	WEDGELOCK™	3 (6.6)
TDS50WR-M	TRS55	TDS50W-M	WEDGELOCK™	3 (6.6)
TDS60WT-1R	TDS60	TDS60WT-1	WEDGETAIL™	6 (13.2)
TDS60WR-M	TRS60	TDS60W-M	WEDGELOCK™	5 (11.0)
TDS70WR-1	TRS70	TDS70W-1	WEDGELOCK™	7 (15.4)
TDS70WT-1R	TDH70	TDS70WT-1	WEDGETAIL™	7 (15.4)
SEAL KITS				
TDS40WS-1	TRS45	TDS40W-1	WEDGELOCK™	.1 (.2)
TDS50WS-M	TRS55	TDS50W-2	WEDGELOCK™	.1 (.2)
TDS60WS-M	TRS60	TDS60W-M	WEDGELOCK™	.1 (.2)
TDS70WS-1	TRS70	TDS70W-1	WEDGELOCK™	.1 (.2)

FX ADAPTER RANGE

www.cqmsrazer.com

DRAWING NO: CG-0072-1 REV NO: C

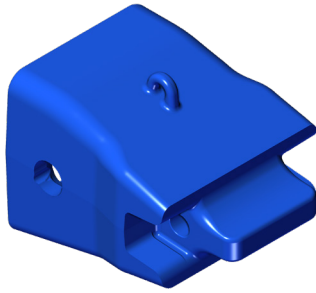
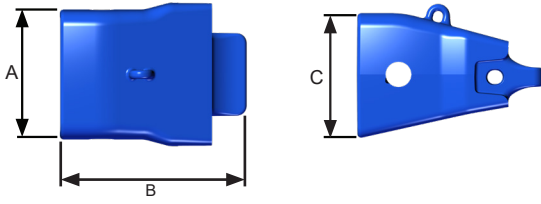

TES1030-500

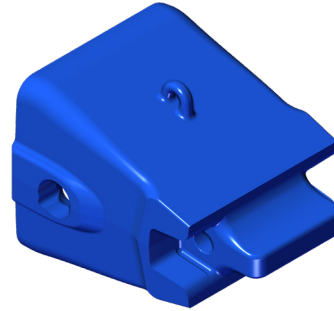

TES3030-500

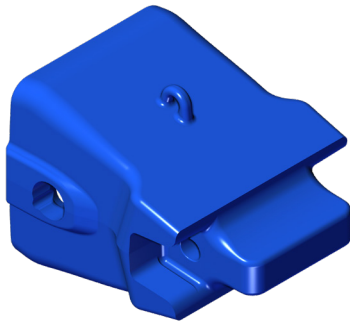

TES3030-750

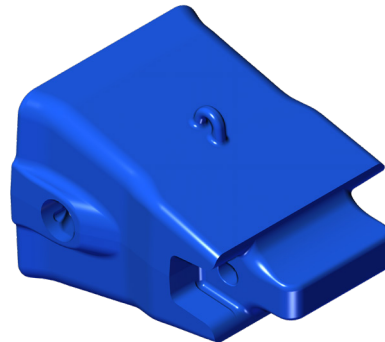

TES4530-750

PART NO.	DIMENSIONS mm (in)			LOCKING KIT	APPLICATION	REPLACES	MASS kg (lbs)
	A	B	C				
TES1030-500	371 (14.61)	482 (18.98)	322 (12.68)	TES10L	STANDARD	S110H92K & S110T92K	183 (402.6)
TES3030-500	401 (15.79)	499 (19.65)	348 (13.70)	TES30L	STANDARD	S130H112K & S130T112K	204 (448.8)
TES3030-750	420 (16.54)	525 (20.67)	365 (14.37)	TES30L	STANDARD	S130H122K & S130T122K	241 (530.2)
TES4530-750	440 (17.32)	569 (22.40)	376 (14.80)	TES45L	STANDARD	S145H122K	257 (565.4)

CAST LIP SHROUDS

www.cqmsrazer.com

DRAWING NO: CG-0018-1 REV NO: E

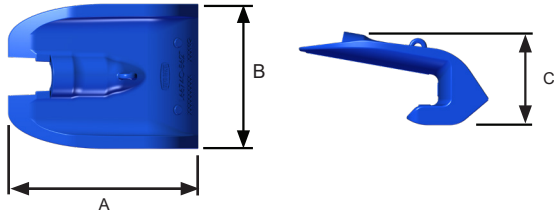

CAST LIP SHROUD EXAMPLE

VALUE ADD

PTAW AND RTO
APPLICATION IS AVAILABLE

PART NO.	DIMENSIONS mm (in)			CAST LIP	T-BOLT KIT	T-BOSS	POSITION	MASS kg (lbs)
	A	B	C					
LSRE1522C	449 (17.68)	335 (13.19)	265 (10.43)	RE1522	M7005	P204TB115	CENTRE	80 (176)
LSRE1522L	478 (18.8)	335 (13.19)	270 (6.69)				LEFT	80 (176)
LSRE1522R	478 (18.8)	335 (13.19)	270 (6.69)				RIGHT	80 (176)
L6974C-381T	557 (21.92)	381 (15.00)	307 (12.08)	RE2526/RE3526	M7011	P6814TB140	CENTRE	107 (235.4)
L6973LC-381T	590 (23.22)	381 (15.00)	307 (12.08)				LEFT	106 (233.2)
L6972RC-381T	590 (23.22)	381 (15.00)	247 (12.08)				RIGHT	106 (233.2)
L6969C-410T	671 (26.41)	410 (16.14)	384 (15.11)	RE4529	M7011	P6814TB140	CENTRE	159 (349.8)
L6971LC-410T	687 (27.04)	410 (16.14)	382 (15.03)				LEFT	151 (332.2)
L6970RC-410T	687 (27.04)	410 (16.14)	377 (14.84)				RIGHT	151 (332.2)
L6566C-320T	683 (26.89)	420 (16.54)	338 (13.31)	RE5534	M7011	P6814TB140	CENTRE	131 (288.2)
L6567RC-320T	690 (27.17)	420 (16.54)	338 (13.31)				LEFT	131 (288.2)
L6568LC-320T	690 (27.17)	420 (16.54)	338 (13.31)				RIGHT	131 (288.2)
L6700C-500T	726 (28.58)	499 (19.65)	353 (13.90)	RE5535	M7011	P6814TB140	CENTRE	206 (453.2)
L6702LC-500T	799 (31.46)	500 (19.69)	353 (13.90)				LEFT	203 (446.6)
L6701RC-500T	798 (31.42)	500 (19.69)	353 (13.90)				RIGHT	203 (446.6)
L6674C-562T	739 (29.09)	561 (22.09)	363 (14.29)	RE5537	M7011	P6814TB140	CENTRE	252 (554.4)
L6675RC-562T	828 (32.60)	562 (22.13)	363 (14.29)				LEFT	249 (547.8)
L6676LC-562T	828 (32.59)	562 (22.12)	363 (14.29)				RIGHT	249 (547.8)

CAST LIP SHROUDS

www.cqmsrazer.com

DRAWING NO: CG-0018-1 REV NO: E

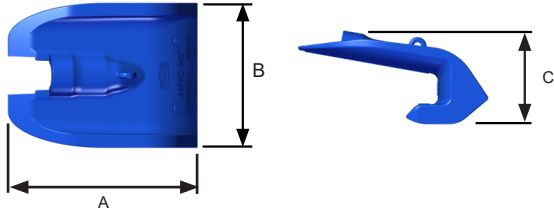

CAST LIP SHROUD EXAMPLE

VALUE ADD

PTAW AND RTO
APPLICATION IS AVAILABLE

PART NO.	DIMENSIONS mm (in)			CAST LIP	T-BOLT KIT	T-BOSS	POSITION	MASS kg (lbs)
	A	B	C					
L6709LC-563T	948 (37.32)	563 (22.16)	282 (11.10)	HD6037	M7020	P6148TB214	LEFT	409 (899.8)
L6708RC-563T	948 (37.32)	563 (22.16)	282 (11.10)				CENTRE	409 (899.8)
LSSR6041C	860 (34.13)	440 (17.32)	392 (15.56)	SR6041	M7011	P6814TB140	CENTRE	237 (521.4)
LSSR6041L	962 (38.17)	440 (17.32)	430 (17.06)				LEFT	231 (508.2)
LSSR6041R	962 (38.17)	440 (17.32)	430 (17.06)				RIGHT	231 (508.2)
L6509C-473T	871 (34.29)	548 (21.57)	384 (15.12)	SR6043	M7011	P6814TB140	CENTRE	274 (602.8)
L6511LC-473T	944 (37.17)	539 (21.22)	383 (15.08)				LEFT	269 (591.8)
L6510RC-473T	944 (37.17)	539 (21.22)	383 (15.08)				RIGHT	269 (591.8)
L6520C-633T	870 (34.25)	708 (27.87)	387 (15.24)	SR6051	M7011	P6814TB140	CENTRE	360 (792.0)
L6522LC-633T	950 (37.40)	703 (27.68)	388 (15.28)				LEFT	348 (765.6)
L6521RC-633T	950 (37.44)	703 (27.68)	388 (15.28)				RIGHT	348 (765.6)
LSSR7043C	999 (39.33)	542 (21.34)	379 (14.92)	SR7043	M7011	P6814TB140	CENTRE	249 (547.8)
LSSR7043L	1075 (42.32)	547 (21.54)	379 (14.92)				LEFT	247 (543.4)
LSSR7043R	1075 (42.32)	548 (21.57)	379 (14.92)				RIGHT	247 (543.4)
L6811C-490T	1017 (40.04)	535 (21.06)	358 (14.09)	SL7043	M7011	P6814TB140	CENTRE	231 (508.2)
L6812LC-490T	1131 (44.53)	535 (21.06)	358 (14.09)				LEFT	218 (479.6)
L6813RC-490T	1131 (44.53)	536 (21.10)	358 (14.09)				RIGHT	218 (479.6)

CAST LIP SHROUDS

www.cqmsrazer.com

DRAWING NO: CG-0018-1 REV NO: E

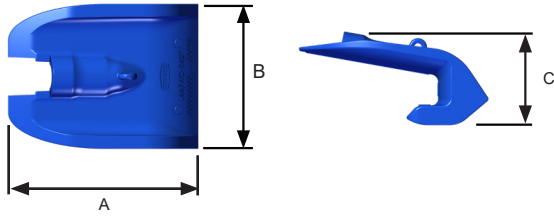

CAST LIP SHROUD EXAMPLE

VALUE ADD

PTAW AND RTO APPLICATION IS AVAILABLE

PART NO.	DIMENSIONS mm (in)			CAST LIP	T-BOLT KIT	T-BOSS	POSITION	MASS kg (lbs)
	A	B	C					
L6537C-699T	792 (31.18)	699 (27.52)	419 (16.50)				CENTRE	375 (825.0)
L6539LC-699T	897 (35.31)	699 (27.52)	426 (16.77)	SR7056	M7012	P388TB166	LEFT	378 (831.6)
L6538RC-699T	897 (35.31)	699 (27.52)	426 (16.77)				RIGHT	378 (831.6)
L6549C-619T	791 (31.14)	619 (24.37)	419 (16.50)				CENTRE	329 (723.8)
L6551LC-619T	889 (35.00)	619 (24.37)	426 (16.77)	SR7051	M7012	P388TB166	LEFT	333 (732.6)
L6550RC-619T	888 (34.96)	619 (24.37)	426 (16.77)				RIGHT	333 (732.6)
LSDE25C	655 (25.79)	407 (16.02)	300 (11.81)				CENTRE	136 (300)
LSDE25L	712 (28.03)	407 (16.02)	303 (11.93)	DE2553/DE2559/ DE2566	M7011	P6814TB140	LEFT	134 (295)
LSDE25R	712 (28.03)	407 (16.02)	303 (11.93)				RIGHT	134 (295)
LSF2510C	657 (25.87)	407 (16.02)	318 (12.52)				CENTRE	157 (345.4)
LSF2510L	711 (27.99)	407 (16.02)	318 (12.52)	DE2559/DE2566	M7011	P6814TB140	LEFT	156 (343.2)
LSF2510R	712 (28.03)	407 (16.02)	318 (12.52)				RIGHT	156 (343.2)
LSDW3554C	482 (18.98)	279 (10.98)	301 (11.85)	DW3554	M7011	P6814TB140	CENTRE	97 (213.4)
LSDS3548C	482 (18.97)	279 (10.98)	310 (12.2)	DS3548	M7011	P6814TB140	CENTRE	10 (224.4)

DRAGLINE LIP SHROUDS

www.cgmsrazer.com

DRAWING NO: CG-0075-1 REV NO: B

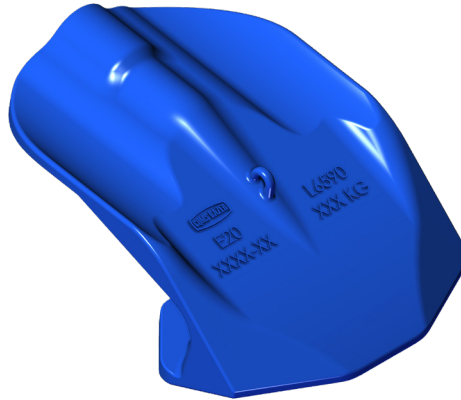
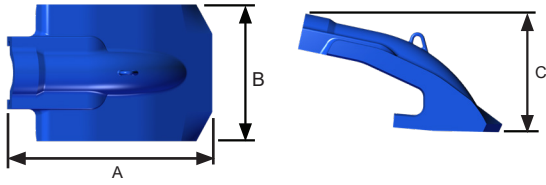

LIP SHROUD EXAMPLE

VALUE ADD
PTAW AND RTO
APPLICATION IS AVAILABLE

PART NO.	DIMENSIONS mm (in)			SUITS BUCKET TYPE	T-BOLT KIT	T-BOSS	MASS kg (lbs)
	A	B	C				
TB1628R	751 (29.57)	380 (14.96)	397 (15.63)	46m ³ (60.1yd ³) EARTHEATER™	M7001	P6098	190 (418.0)
TB1728	703 (27.68)	470 (18.50)	408 (16.06)	57m ³ (74.5yd ³) EARTHEATER™	M7000	P6147	233 (512.6)
L2615	819 (32.24)	600 (23.62)	464 (18.27)	84m ³ (109.8yd ³) EARTHEATER™	M7000	P6147	388 (853.6)
L6647	815 (32.09)	680 (26.77)	458 (18.03)	84m ³ (109.8yd ³) EARTHEATER™	M7001	P6098	388 (853.6)
L2193	748 (29.45)	610 (24.02)	399 (15.71)	46m ³ (60.1yd ³) ROCK BUCKET	M7020	P6148TB214	263 (578.6)
L2415	673 (26.50)	480 (18.90)	392 (15.43)	24m ³ (31.3yd ³) SCOOP	M7020	P6148	180 (396.0)
L2140	748 (29.45)	507 (19.96)	435 (17.13)	38m ³ (49.7yd ³) SCOOP	M7020	P6148	234 (514.8)
L6548	640 (25.20)	412 (16.22)	358 (14.09)	24m ³ HURRICANE™	M7011	P6814TB140	133 (293.2)
L6670	802 (31.57)	580 (22.83)	442 (17.40)	46m ³ (60.1yd ³) HURRICANE™	M7000	P6147	301 (663.5)
L6515	846 (33.31)	620 (24.41)	384 (15.12)	57m ³ (74.5yd ³) HURRICANE™	M7000	P6147	351 (772.2)
L6590	924 (36.38)	690 (27.17)	481 (18.94)	70m ³ (91.5yd ³) HURRICANE™	M7000	P6147	451 (992.2)
L2135	961 (37.83)	759 (29.88)	498 (19.61)	84m ³ (109.8yd ³) HURRICANE™	M7000	P6147	559 (1229.8)
L6565	961 (37.83)	815 (32.09)	541 (21.30)	100m ³ (130.7yd ³) HURRICANE™	M7000	P6147	673 (1480.6)

CAST LIP WING SHROUDS

www.cqmsrazer.com

DRAWING NO: CG-0021-1 REV NO: F

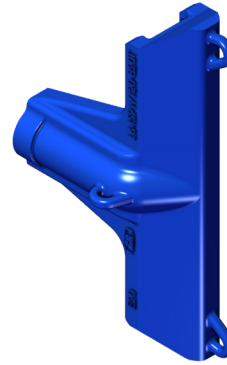
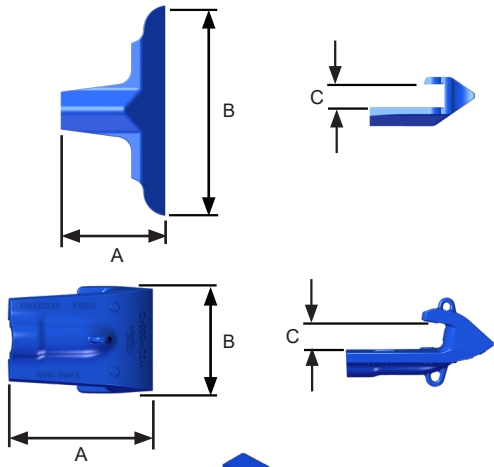

UPPER WING SHROUD EXAMPLE

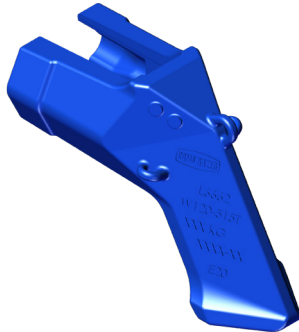

LOWER WING SHROUD EXAMPLE

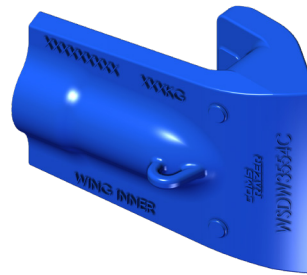

ROPE SHOVEL WING SHROUD EXAMPLE

VALUE ADD

PTAW AND RTO APPLICATION IS AVAILABLE

PART NO.	DIMENSIONS mm (in)			CAST LIP	T-BOLT KIT	T-BOSS	POSITION	MASS kg (lbs)
	A	B	C					
WS50U	328 (12.9)	783 (30.8)	53 (2.08)	RE1522	M7005	P3908TB115	UPPER	63 (138.6)
L6558W70-840T	420 (16.54)	839 (33.03)	73 (2.87)	RE2526/RE3526/RE4529/RE5534	M7005	P3908TB115	UPPER	85 (187.0)
L6618W80-840T	420 (16.54)	839 (33.03)	83 (3.27)	DE2559/DE2566	M7005	P3908TB115	UPPER	79 (173.8)
L6556W90-840T	420 (16.54)	839 (33.03)	93 (3.66)	RE5535/RE5537	M7005	P3908TB115 P204TB115^	UPPER	83 (182.6)
L6459W120-820T	410 (16.14)	820 (32.28)	123 (4.84)	HD6037/SR6043/SR6051/SR7043/ SL7043	M7002	P3901TB130	UPPER	136.1 (299.4)
L6890W140-820T	410 (16.14)	820 (32.28)	143 (5.63)	SR7056/SR7051	M7002	P3901TB130	UPPER	148 (325.6)
WSRE1522L	397 (15.63)	433 (17.05)	73 (2.87)	RE1522	M7005	P204TB115	LOWER	70 (154)
L6659W70-380T	373 (14.68)	380 (14.96)	73 (2.87)	RE2526/RE3526	M7005	P204TB115	LOWER LEFT/RIGHT	52 (114.4)
L6589 L6588	494 (19.45)	295 (11.61)	96 (3.78)	RE4529/RE5534/RE5535/RE5537	M7005	P204TB115 * P3908TB115	LOWER LEFT LOWER RIGHT	50 (110.0)
L6662W120-515T	736 (28.97)	515 (20.27)	123 (4.84)	HD6037/SR6041/SR6043/SR6051/ SR7043/SL7043	M7011	P265TB140	LOWER LEFT/RIGHT	156 (343.2)
L6433LW140-658T L6434RW140-658T	681 (26.81)	654 (25.75)	143 (5.63)	SR7056/SR7051	M7004	P362TB140	LOWER LEFT LOWER RIGHT	178 (391.6)
WSDW3554C	534 (21.02)	394 (15.51)	88 (3.46)	DW3554	M7011	P6814TB140	CENTRE	123 (271.1)
WSDW3554L	534 (21.02)	404 (15.90)	88 (3.46)	DW3554	M7011	P6814TB140	LEFT	124 (273.3)
WSDW3554R	534 (21.02)	405 (15.94)	88 (3.46)	DW3554	M7011	P6814TB140	RIGHT	124 (273.3)
WSDS3548LU WSDS3548RU	495 (19.48)	629 (24.76)	89 (3.5)	DS3548	M7011	P6814TB140	UPPER LEFT UPPER RIGHT	136 (299.2)
WSDS3548LL WSDS3548RL	665 (26.18)	681 (26.81)	89 (3.5)	DS3548	M7011	P6814TB140	LOWER LEFT LOWER RIGHT	190 (418)

*For RE4529 only. *For RE5535 only

46/57m³ CLASS HURRICANE™ WING SHROUDS

www.cqmsrazer.com

DRAWING NO: CG-0073-1 REV NO: B

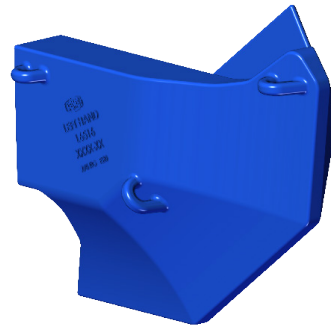
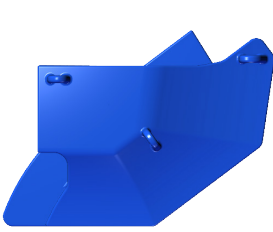

L6516 (LEFT HAND)
L6517 (RIGHT HAND)

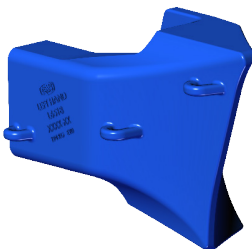

L6518 (LEFT HAND)
L6519 (RIGHT HAND)

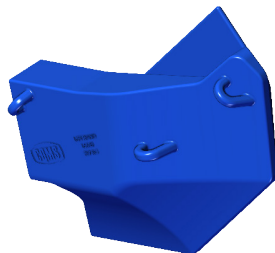

L6668 (LEFT HAND)
L6669 (RIGHT HAND)



L6666 (LEFT HAND)
L6667 (RIGHT HAND)



L6965 (LEFT HAND)
L6966 (RIGHT HAND)

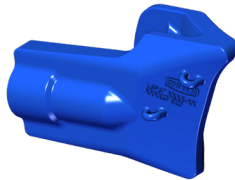

L6967 (LEFT HAND)
L6968 (RIGHT HAND)



L6975 (LEFT HAND)
L6976 (RIGHT HAND)



L6977 (LEFT HAND)
L6978 (RIGHT HAND)

VALUE ADD

PTAW AND RTO
APPLICATION IS AVAILABLE

PART NO.	POSITION	T-BOLT KIT	T-BOSS	BUCKET CLASS	MASS* kg (lbs)
L6666	LOWER LEFT	M7001	P6098	46m ³ (60.1yd ³)	159 (349.8)
L6667	LOWER RIGHT	M7001	P6098	46m ³ (60.1yd ³)	221 (486.2)
L6668	UPPER LEFT	M7000	P299TB214	46m ³ 2.0 (60.1yd ³)	234 513.7
L6669	UPPER RIGHT	M7000	P299TB214	46m ³ 2.0 (60.1yd ³)	181.08 (398.4)
L6516	UPPER LEFT	M7001	P6098	57m ³ (74.5yd ³)	276 (607.2)
L6517	UPPER RIGHT	M7001	P6098	57m ³ (74.5yd ³)	194 (426.8)
L6518	LOWER LEFT	M7000	P299TB214	57m ³ 2.0 (74.5yd ³)	271 (596.2)
L6519	LOWER RIGHT	M7000	P299TB214	57m ³ 2.0 (74.5yd ³)	222 (488.4)

70/84/100m³ CLASS HURRICANE™ WING SHROUDS

www.cqmsrazer.com

DRAWING NO: CG-0073-1 REV NO: B



L6982 (LEFT HAND)
L6983 (RIGHT HAND)

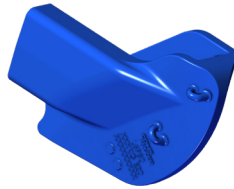

L6980 (LEFT HAND)
L6981 (RIGHT HAND)



L6984 (LEFT HAND)
L6985 (RIGHT HAND)

VALUE ADD

PTAW AND RTO
APPLICATION IS AVAILABLE

PART NO.	POSITION	T-BOLT KIT	T-BOSS	BUCKET CLASS	MASS kg (lbs)
L6980	UPPER LEFT	M7001	P6098	70/84/100m ³ (91.5/109.8/130.7yd ³)	241.84 (532.0)
L6981	UPPER RIGHT				
L6982	LOWER LEFT	M7001	P6098	70m ³ (91.5yd ³)	294.31 (647.5)
L6983	LOWER RIGHT				
L6984	LOWER LEFT	M7001	P6098	84/100m ³ (109.8/130.7yd ³)	361.15 (794.5)
L6985	LOWER RIGHT				

46/57m³ CLASS EARTHEATER™ WING SHROUDS

www.cqmsrazer.com

DRAWING NO: CG-0074-1 REV NO: B

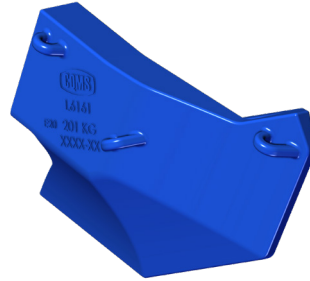
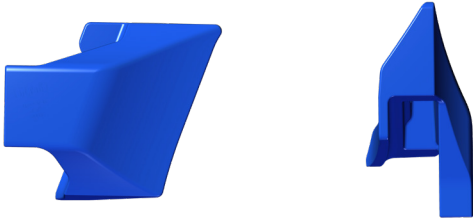

L6161 (LEFT HAND)
L6162 (RIGHT HAND)

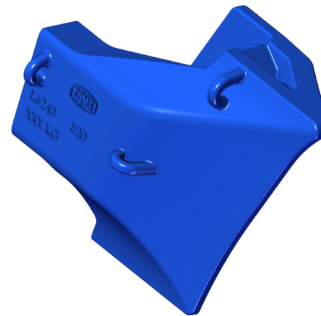
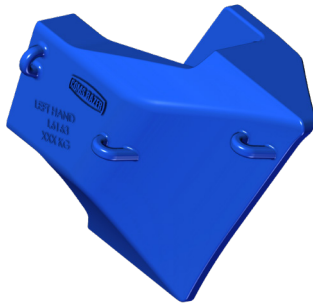

L6163 (LEFT HAND)
L6164 (RIGHT HAND)

L6243 (LEFT HAND)
L6244 (RIGHT HAND)

VALUE ADD
PTAW AND RTO
APPLICATION IS AVAILABLE

PART NO.	POSITION	T-BOLT KIT	T-BOSS	BUCKET CLASS	MASS kg (lbs)
L6161	UPPER LEFT	M7001	P6098	46m ³ (60.1yd ³)	202 (444.4)
L6162	UPPER RIGHT				
L6163	LOWER LEFT	M7001	P6098	46m ³ (60.1yd ³)	204 (448.8)
L6164	LOWER RIGHT				
L6243	LOWER LEFT	M7001	P6098	57m ³ (74.5yd ³)	201 (442.2)
L6244	LOWER RIGHT				

84m³ CLASS EARTHEATER™ WING SHROUDS

www.cqmsrazer.com

DRAWING NO: CG-0074-1 REV NO: B

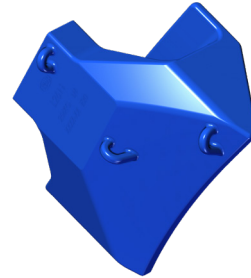

L2611 (LEFT HAND)
L2612 (RIGHT HAND)

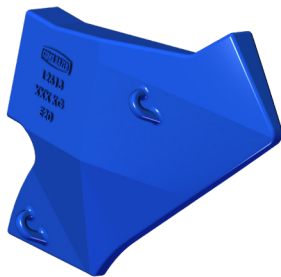

L2613 (LEFT HAND)
L2614 (RIGHT HAND)

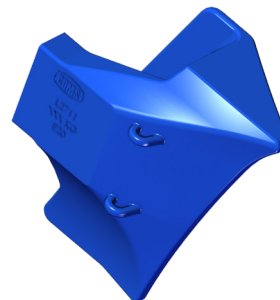

L2711 (LEFT HAND)
L2712 (RIGHT HAND)

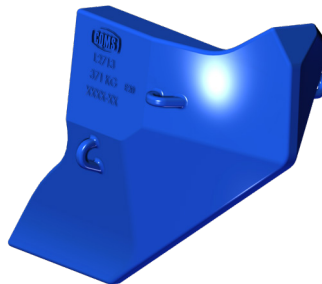

L2713 (LEFT HAND)
L2714 (RIGHT HAND)

VALUE ADD
PTAW AND RTO
APPLICATION IS AVAILABLE

PART NO.	POSITION	T-BOLT KIT	T-BOSS	BUCKET CLASS	MASS kg (lbs)
L2611	LOWER LEFT	M7001	P6098	84m ³ (109.8yd ³)	256
L2612	LOWER RIGHT				
L2613	UPPER LEFT	M7001	P6098	84m ³ (109.8yd ³)	307
L2614	UPPER RIGHT				

SHEAR BLOCKS

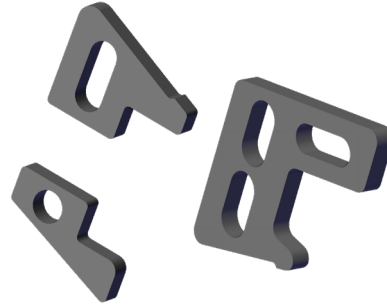

GWSK-0019

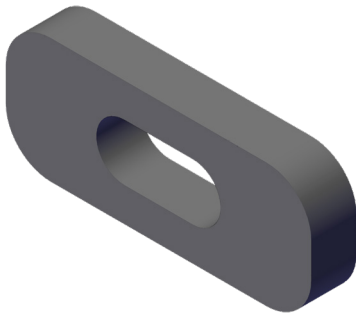

GWS-0058

PART NO.	DIMENSIONS mm (in)	POSITION	WING SHROUD APPLICATION		CAST LIP	MASS kg (lbs)
	A		LEFT	RIGHT		
GWSK-0019	20 (0.78)	LOWER	L6589	L6588	RE4529, RE5535, RE5534, RE2526, RE5537	5 (11.0)
GWS-0059	16	UPPER AND LOWER	WS50U, WSRE1522L		RE1522	1.1 (2.42)
GWS-0058	40 (1.57)	UPPER AND LOWER	ALL OTHER WING CAST LIP WING SHROUDS		ALL CAST LIPS	7.3 (16.1)

WELDMENTS

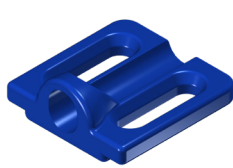
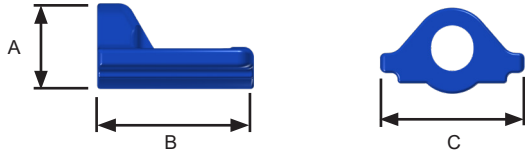

P204TB115

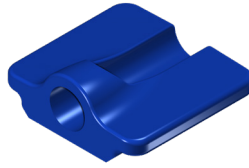

P265TB140

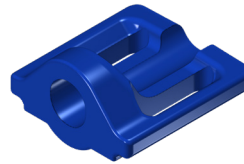

P362TB140

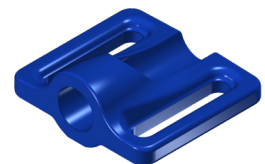

P388TB166

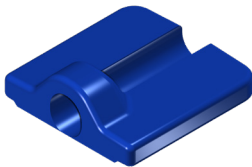

P3901TB130

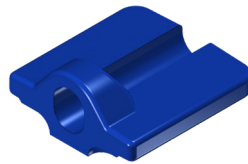

P3908TB115

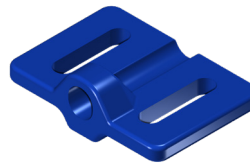

P6148TB214

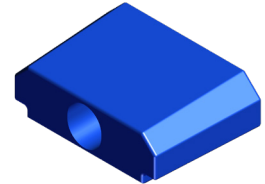

P6098

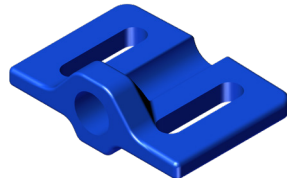

P6147

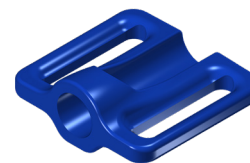

P6814TB140

PART NO.	DIMENSIONS mm (in)			T-BOLT KIT	SHROUD	MASS kg (lbs)
	A	B	C			
P204TB115	51 (2.01)	118 (4.65)	115 (4.53)	M7005	L6566, L6588, L6589, L6659	1.4 (3.1)
P3908TB115	55 (2.17)	118 (4.65)	115 (4.53)	M7005	L6558, L6556, L6618, L6589, L6588	2.4 (5.3)
P265TB140	60 (2.36)	130 (5.12)	140 (5.51)	M7011	L6662	3 (6.6)
P3901TB130	60 (2.36)	133 (5.24)	130 (5.12)	M7002	L6459, L6890	3.5 (7.7)
P388TB166	70 (2.76)	150 (5.91)	166 (6.54)	M7012	L6537, L6539, L6538, L6549, L6551, L6550	3.5 (7.7)
P6148TB214	70 (2.76)	150 (5.91)	214 (8.43)	M7020	L2193, L6398, L6399, L6400, L6709, L6708	5.1 (11.2)
P6098	75 (2.95)	120 (4.72)	180 (7.09)	M7001	TB1628R, L2611, L2612, L2613, L2614, L6161, L6162, L6163, L6164, L6243, L6244, L6516, L6517, L6518, L6519, L6647, L6666, L6667, L6668, L6669, L6980, L6981, L6982, L6983, L6984, L6985	8.7 (19.1)
P6147	75 (2.95)	150 (5.91)	213 (8.39)	M7000	TB1728, L2615, L6670, L6515, L6590, L2135, L6565	5 (11.0)
P6814TB140	57 (2.24)	130 (5.12)	140 (5.51)	M7011	L6548, L6974, L6973, L6972, L6969, L6970, L6971, L6566, L6567, L6568, L6700, L6701, L6702, L6674, L6675, L6676, L6509, L6510, L6511, L6520, L6521, L6522, L6631, L6632, L6633, L6811, L6812, L6813, LSF2510C, LSF2510L, LSF2510R, LSDW3554C, WSDW3554C, WSDW3554R, WSDW3554L	2 (4.4)
P362TB140	83 (3.27)	152 (5.98)	140 (5.51)	M7004	L6433, L6434, L6967, L6968	3.9 (8.6)
P299TB214	86 (3.38)	150 (5.91)	212 (8.35)	M7000	L6965, L6966, L6967, L6968, L6975, L6976, L6977, L6978	9.46 (20.8)

T-BOLT KITS

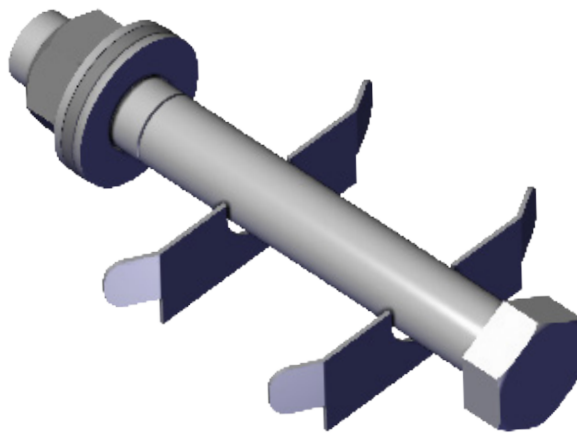

STANDARD
M7002

PART NO.	DIMENSIONS mm (in)			BOLT SIZE D=Diameter L=Length	RETAINS	MASS kg (lbs)
	A	B	C			
M7000	305 (12.00)	220 (8.66)	82 (3.22)	1-1/2"Dx11"L	L6965, L6966, L6967, L6968, L6975, L6976, L6977, L6978, TB1728, L2615, L6670, L6515, L6590, L2135, L6565	4 (8.8)
M7001	254 (10)	170 (6.69)	80 (3.14)	1-1/2"Dx9"L	TB1628, L6647, L2611, L2612, L2613, L2614, L6161, L6162, L6163, L6164, L6243, L6244, L6666, L6667, L6668, L6669, L6516, L6517, L6518, L6519, L6980, L6981, L6982, L6983, L6984, L6985	3.5 (7.7)
M7002	247 (9.72)	135 (5.31)	55 (2.16)	1 1/8"Dx9"L	L6459, L6890	2 (4.4)
M7004	305 (12.00)	148 (5.82)	88 (3.46)	1 1/2"Dx11"L	L6433, L6434	4 (8.8)
M7005	219 (8.62)	122 (4.80)	56 (2.20)	1"Dx8"L	L6588, L6618, L6556, L6659, L6589, L6588	1 (2.2)
M7011	249 (9.80)	146 (5.74)	33 (1.29)	1 1/4"Dx 9"L	L6662, WSDW3554C, WSDW3554L, WSDW3554R, L6548, L6972, L6973, L6974, L6969, L6970, L6971, L6566, L6567, L6568, L6700, L6701, L6702, L6674, L6675, L6676, L6509, L6510, L6511, L6520, L6521, L6522, L6631, L6632, L6633, L6811, L6812, L6813, LSF2510C, LSF2510L, LSF2510R, LSDW3554C	2 (4.4)
M7012	305 (12.00)	174 (6.85)	88 (3.46)	1-1/2"Dx11"L	L6549, L6550, L6551, L6537, L6538, L6539	4 (8.8)
M7020	302 (11.88)	220 (8.66)	68 (2.67)	1-1/4"Dx11"L	L2193, L2415, L2140, L6398, L6399, L6400, L6709, L6708	3 (6.6)

HEEL SHROUDS

www.cqmsrazer.com

DRAWING NO: CG-0080-1 REV NO: A

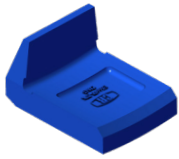
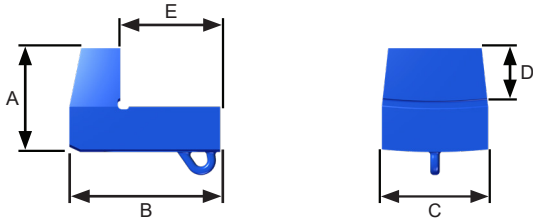

ES6697-2PX

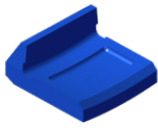

ES6697-3PX

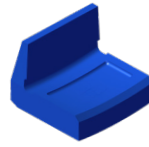

ES6697-4PX



ES6697-5PX

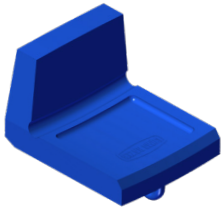

ES6697-5APX

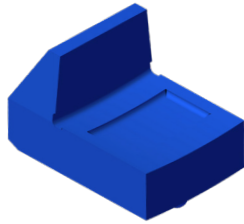

ES6697-7PX

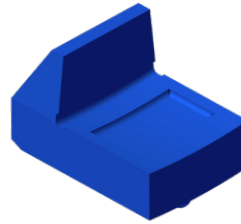

L6922

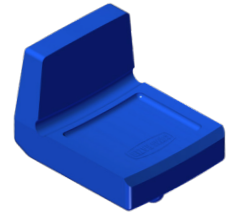

ES6697-5HDPX

PART NO.	DIMENSIONS mm (in)					MACHINE SIZE	MASS kg (lbs)
	A	B	C	D	E		
ES6697-2PX	150 (5.91)	250 (9.84)	188 (7.4)	94 (3.7)	200 (7.87)	80-180T	21 (46.2)
ES6697-3PX	100 (3.98)	200 (7.87)	188 (7.4)	56 (2.2)	150 (5.91)	40-80T	13 (28.6)
ES6697-4PX	150 (5.91)	175 (6.89)	188 (7.4)	94 (3.7)	135 (5.31)	20-40T	16 (35.2)
ES6697-5PX	200 (7.87)	300 (11.81)	250 (9.84)	144 (5.7)	235 (9.25)	180-550T	38 (83.6)
ES6697-5APX	206 (8.11)	300 (11.81)	250 (9.84)	150 (5.91)	235 (9.25)	180-550T	40 (88)
ES6697-7PX	244 (9.6)	355 (13.98)	250 (9.84)	144 (5.7)	235 (9.25)	550-1000T	82 (180.4)
L6922	244 (9.6)	355 (13.98)	250 (9.84)	138 (5.43)	235 (9.25)	550-1000T	89 (195.8)
ES6697-5HDPX	226 (8.89)	300 (11.81)	250 (9.84)	150 (5.91)	235 (9.25)	180-550T	52 (114.4)

© 2018, CQMS Razer Pty Ltd (“The Publisher”)
www.cqmsrazer.com

ALL RIGHTS RESERVED. The material contained in this catalogue are the copyright of the publisher and any unauthorised reprint or use of this material is prohibited unless permission is granted by the publisher. All Trade Marks shown are the property of CQMS Razer Pty Ltd and may only be used in relation to the goods and services of this company or its licensees. The material in this catalogue has been detailed with accuracy however no liability can be accepted for any loss or damage arising out of the use of the information contained herein.

Part of the CR Group

www.cqmsrazer.com